

NorthCoast 315 Hard Top

By C & C Marine, Inc

Owner's Manual



315 CABIN

General Specifications

L.O.A: 35' - 0"

Beam (Max): 10' - 2"

Draft (Hull): 1' - 9"

Dead rise (Transom): 23 degrees

Full Weight: 12,212 lbs.

Power (max) 600 hp

Fuel: 300-gallon usable fuel

Better Design, Superior Construction

Date: 7/30/20

Table of Contents

1) INTRODUCTION	Page 3
Dealer & Owner Responsibilities	
2) SAFETY	Page 5
Rules of the Road	
3) ELECTRICAL	Page 6
Electrical Schematic	
4) PLUMBING	Page 13
Plumbing Schematic	
Baitwell Operation	
5) CONTROLS	Page 21
Steering	
Shift & Throttle	
Trim Tabs	
Instrumentation	
6) FUEL SYSTEM	Page 22
Fuel System Operation	
Schematic	
7) VESSEL OPERATION	Page 29
Weight	
Fueling	
Trim	
Trim Tabs	
Starting	
8) MAINTENANCE	Page 31
Fiberglass and Gelcoat	
Other Exterior Components	
Winterization, Storage and Commissioning	
9) Construction Details	Page 35
10) Commissioning Checklist	Page 37
11) STANDARD EQUIPMENT	Page 39
Optional Equipment	
12) SPECIFICATIONS & INFORMATION	Page 44
13) WARRANTY	Page 47
Warranty Policy	
Warranty Registration	
Warranty Transfer	
14) TOOLS AND EQUIPMENT	Page 50
15) LOADING YOUR BOAT	Page 51

INTRODUCTION

WELCOME! You are now a member of the C&C Marine family. We want to thank you for joining us with the purchase of your NorthCoast 315 Hard Top.

The NorthCoast 315 Hard Top hull style provides the most comfortable ride in demanding conditions. All materials used in this model are of the highest quality from reliable domestic vendors. The boat is constructed in accordance with American Boat and Yacht Council (ABYC) standards and The Code of Federal Regulations, section 33 as applicable.

This manual and the accompanying equipment documentation are intended to provide you with information necessary for the proper operation of the NorthCoast 315 Hard Top. Take the time to review all literature. Get to know your boat. This manual is not a safe boating guide.

Dealer Responsibilities

Your dealer's responsibilities include, but are not limited to:

- Pre-delivery verification of proper rigging and operation.
- Provide adequate orientation for the general operation of your NorthCoast. This should be a system walkthrough with a full explanation of safe and proper operation.
- An explanation and review of the owner's packet.
- Jointly complete all warranty cards and product registrations.

Owner Responsibilities

As the vessel owner, your responsibilities include, but are not limited to:

- Be proficient in boat handling, operation, rules of the road, navigation and so forth.

THIS MANUAL IS NOT INTENDED TO SUBSTITUTE FOR THE GENERAL ASPECTS OF BOAT HANDLING, NAVIGATION OR ANY OTHER SAFETY ISSUES.

- Read and understand the limited warranty.
- Read all literature and instructions.
- Use and maintain all equipment as directed.
- Perform a thorough examination and sea-trial at the time of delivery.
- Learn about and operate your vessel in accordance with all local, state and federal laws, regulations and registration requirements.

You alone are legally responsible for all liabilities of operation.

Make sure to obtain appropriate insurance coverage.

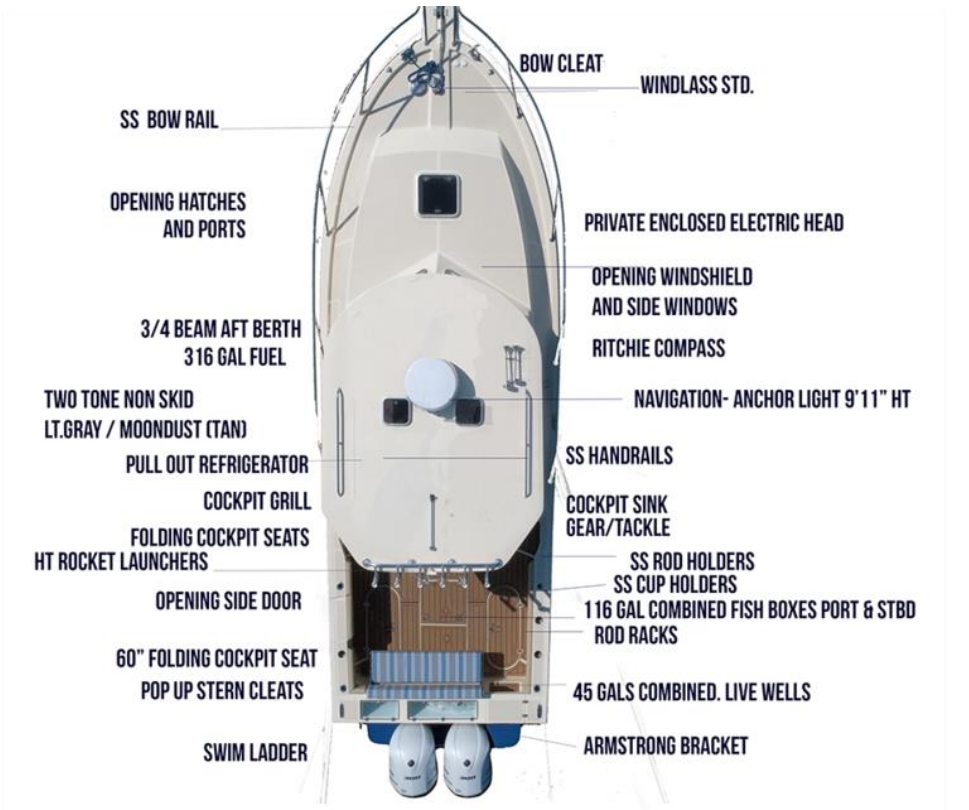

SAFETY

Your NorthCoast 315 Hard Top has been designed and constructed with safety in mind. As mentioned, the hull form provides the best sea-keeping ability for all-around recreational use. However, the safety of you and your passenger's rests solely with the owner. The U. S. Coast Guard (USCG) is the governing authority for U. S. waters. As such, the owner should become familiar the rules of the road and stay current with USCG boating safety circulars. There are numerous publications available from the USCG. To obtain this information, visit www.boatingsafety.com or call the boating safety hotline at 1-800-368-5647.

US Coast Guard Equipment

USCG Regulations require certain equipment be maintained and carried aboard your boat at all times. The equipment includes:

Fire Extinguisher
One Type II Personal Flotation Device (PFD) for each occupant
One Type IV PFD
Sound Signal Device
Navigation Lights when operating at night
Sight Signal Flare Kit
Anchor and Sufficient Line

THESE REQUIREMENTS ARE SUBJECT TO CHANGE. IT IS THE OWNER'S RESPONSIBILITY TO MAINTAIN THE NECESSARY EQUIPMENT.

Rules of the Road

The USCG conducts boating safety classes on a regular basis in all regions of the country. If you are not familiar with the rules for safe boating, you should take a class. Some basic highlights for safe operation and navigation include:

- A vessel under power shall yield to a vessel under sail.
- An overtaking vessel shall keep clear of the vessel ahead.
- Commercial vessels have right of way over recreational vessels.
- Know and observe navigational buoys, markers and other aids to navigation.
- Vessels approaching head on shall pass Port to Port.
- A vessel approaching from starboard has right of way.

ELECTRICAL

Electrical System

A direct current electrical system is provided. The system is comprised of one Group 24 starting battery, rated at 800CCA. This is located in the battery box under the seat. The boat is supplied with a battery selector switch located at the helm on the starboard side outboard. The battery switch supplies the two fuse panels located on the forward face of the helm station inside the cabin. The sizes, labels and functions are as shown:

SWITCH POSITION WHEN RUNNING TWIN ENGINES AND HOUSE

HOUSE BATTERY
POSITION ON



STBD. ENGINE
POSITION ON

PORT ENGINE
POSITION ON

EMERGENCY PARRALLEL SWITCH USED ONLY TO START AN ENGINE BATTERY THAT DOES NOT HAVE THE CAPACITY TO START THE ENGINE.
(THE SWITCH SHOULD NOT BE LEFT ON NO LONGER THAN 10min.)

REVISIONS

NO.	DESCRIPTION	DATE
1	ADDED ATTENTION NOTE	5/11/23

ATTENTION:
 1: THE INVERTER BATTERY SWITCH MUST BE TURNED OFF BEFORE PLUGGING IN THE SHORE POWER OR SWITCHING TO GENERATOR!
 THE RESULT OF NOT DOING SO WILL BE THE ELCI MAIN BREAKER ON THE AC PANEL WILL TRIPP AND LEAVE THE AC PANEL INOPERABLE.

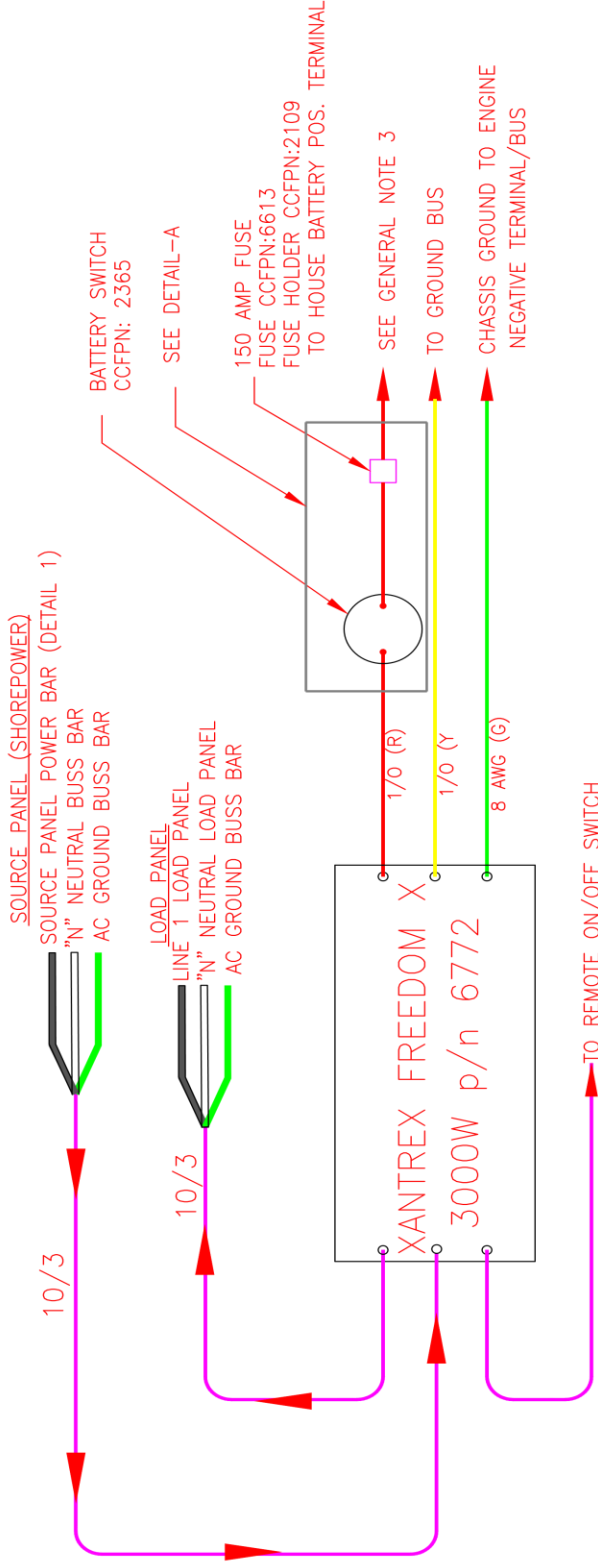

OPTIONAL 110V AC INVERTER SYSTEM

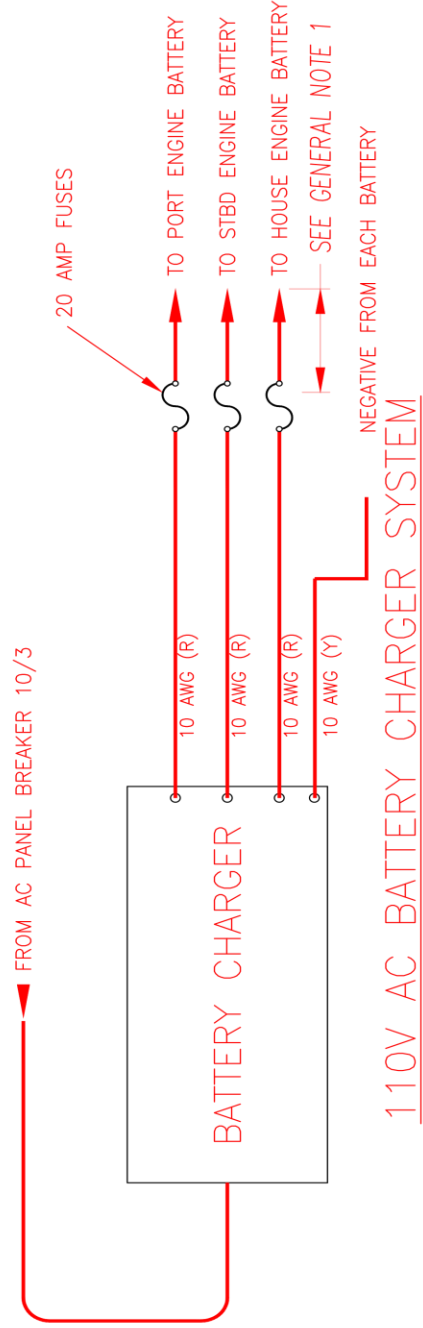

C & C FIBERGLASS
 COMPONENTS INC

75 DILLON BLVD BRISTOL, RI 02809 USA
 PHONE: (401) 254-4342 FAX: (401) 254-8978

110VAC & BATTERY CHGR

DWG. NO: NC315HT501 PAGE 2 OF 3

SCALE: NONE DATE: 2/04/21
 DRAWN BY: RJP

THIS DOCUMENT IS THE PROPERTY OF C&C.FI AND IS NOT TO BE
 USED OR REPRODUCED IN WHOLE OR IN PART WITHOUT EXPRESS PERMISSION

ELECTRICAL SYSTEMS

12 VOLT DC SYSTEM

- **PANEL DESCRIPTION**

The DC main electric panel distributes the ship's power from the house batteries and protects each electrical component and associated ship's wiring from overcurrent situations. One battery switch is used to select which battery will supply power to the panel's main DC circuit breaker. The panel's main breaker protects the internal panel wiring from potential dangers caused by operating more electrical components than the panel can safely handle. It may be used like a switch to turn the entire system on and off. Each electrical component is activated by a separate circuit breaker sized specifically for that component and wiring. The panel includes a voltmeter to evaluate the quality of power supplied by the battery.
- **OPERATING PROCEDURES AND PRECAUTIONS**

Prior to operating the electrical panel, use the "House" battery switch to supply the power. Use the battery test switch to verify sufficient voltage to operate the system. Turn on the panel main breaker and the individual breakers as desired. Before leaving the boat, turn off the main breaker and the battery switch.
- **BATTERY SWITCH**

One rotary switch is mounted under by the helm station. These UL listed switches allow power to go from the house batteries to the main DC panel. The engine batteries can be supplemented temporarily with the house batteries by means of the paralleling switch at the helm station. The engine batteries cannot be used in parallel with the house batteries to power the main DC panel. The battery #1 battery #2 tester on the main DC panel is for checking the status of the individual house battery banks. Industry convention uses battery #1 as the "House" battery bank and battery #2 as the Engine battery bank. Battery bank #1 consists of two batteries wired in parallel to increase its capacity.
- **BATTERY TEST SWITCH**

The voltmeter installed on the electrical panel will give an indication of the charge status of each of the house batteries. The voltmeter should read between 12.8V and 13.2V for a fully charged battery. When the engine is charging the battery, the meter should read between 14.2V and 14.8V.
- **MINIMUM VOLTAGE REQUIREMENTS**

As the power is used from the battery, the voltage supplied is reduced. To prevent damage to electrical components, especially motors, do not operate the electrical system if less than 11.0V is available.
- **INDIVIDUAL CIRCUIT BREAKERS**

Like the main breaker, the individual circuit breakers are designed to function as switches as well as provide overcurrent protection. Space is provided for additional breakers if optional electrical equipment is installed. We recommend that the individual breakers be activated only as needed and left off otherwise.
- **CABIN LIGHTS -- FORWARD**

All of the cabin lights in the forward cabin are activated by this circuit breaker.

- **NAVIGATION LIGHTS**
 This circuit breaker activates the running lights switch at the helm station for the red and green side lights, the stern light in the transom, and the masthead or steaming light. These lights provide the proper lighting required by law for operation at night under power.
- **ANCHOR LIGHT**
 This circuit breaker activates the Anchor Light switch at the helm station. This light is required by law when anchoring at night outside established anchorages.
- **COCKPIT LIGHTS**
 The cockpit courtesy lights are activated by this circuit breaker.
- **HORN**
 The momentary switch at the helm station for the horn is controlled by this circuit breaker.
- **STEREO**
 This circuit breaker provides power to the stereo. Both the breaker and the stereo itself must be on for the stereo to operate.
- **WASHDOWN PUMP**
 This circuit breaker provides power to the optional washdown pump.
- **INSTRUMENTS**
 All of the instruments are activated by this circuit breaker.
- **VHF RADIO/TRANSMITTER**
 The VHF radio is activated by this circuit breaker. The radio itself has a switch which must be turned on for it to operate.
- **SPARE**
 This circuit breaker is provided for the addition of electrical equipment. Be sure not to exceed its capacity when installing additional equipment.
- **BILGE PUMPS**
 The electric bilge pumps are wired directly to the batteries and are always active as long as there is power in the batteries. Each circuit has a 15 amp in-line fuse located under the helm console. The pumps can be operated by manual switches or be set to the float switches from the helm station panel.
- **BATTERIES**
 The batteries are sealed type which do not require any maintenance. If for any reason a battery needs to be replaced ensure that another is used as charging rates vary with different types of batteries.

BONDING AND LIGHTNING PROTECTION

- **BONDING SYSTEM**

To reduce galvanic action caused by different metals in close proximity to each other, all major metal masses are bonded (wired) together including the engine in accordance with ABYC.

- **LIGHTNING PROTECTION**

In spite of the bonding system, there can be no assurances that personnel or the boat will not suffer damage or injury if the vessel is hit by lightning. The following, adapted from the ABYC safety standards, are suggestions only and in no way guarantee safety.

- 1) If possible, remain inside the boat and close all hatches during a lightning storm. Do not contact any metallic objects or components of the electrical system inside the vessel.
- 2) Avoid making contact with any items connected to the bonding system (engines, generator, thru-hulls, etc.) and especially in a way to bridge between two of them.
- 3) No one should be in the water during a lightning storm.
- 4) If the boat has been struck by lightning, the compass and all electrical gear should be checked to determine that no damage or change in calibration has occurred.

PLUMBING

Bilge Pump

The bilge pump is located in the bilge pump compartment aft at the transom. The bilge discharge is located starboard at the sheer.

Saltwater Washdown (optional)

The saltwater washdown spigot is located on the transom, port side. The saltwater is fed from a pump, located on the transom, port side. The saltwater pump inlet is located aft in the bilge pump compartment.

NOTE:

1. Operator must open intake seacock to use Saltwater Washdown or Baitwell.
2. When not in use, the power switch should be off and seacock valve(s) closed.

BAITWELL

Baitwell Operation

The baitwell is located aft at the transom. The baitwell is filled via the aerator spigot. The water is supplied by the saltwater washdown system. The baitwell is filled by placing the overflow drain tube into the fitting at the bottom of the baitwell. To drain the baitwell simply unscrew the tube until the drain holes in the threaded fitting are exposed. The baitwell drains overboard unassisted to the port side at the boot top.

Your Baitwell supplied with a 1600GPH Tournament Series Live Well-Baitwell pump 209B. Follow Operation procedures below.

Operation:

1. Open Seacock
2. Turn pump on
3. The tank will fill until water runs out the overflow pipe
4. Leave pump on for continuous exchange of water
5. **When system is not in use close seacock. There is NO built in check valves when underway
Pressure will build up in the lines.**
6. **Reducing the water flow at the seacock or aerator will not damage the pump.**
7. **Leaving the pump in the on position and the aerator closed will eventually for long
Periods of time will damage the pump.**

REVISIONS

NO.	DESCRIPTION	DATE
1	Added wire sizes	1/20/20
2	Added Seawater strainer Info	1/31/20



3/8" GROCO BRONZE SEACOCK

3/8" GROCO BRONZE SEAWATER STRAINER

PUMP ASY PML500 115/50-60/1

AIR CONDITION PUMP ASSEMBLY

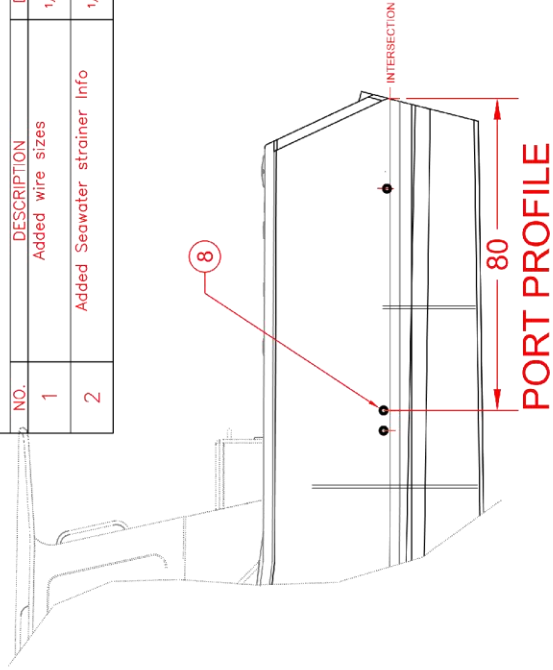

PORT PROFILE

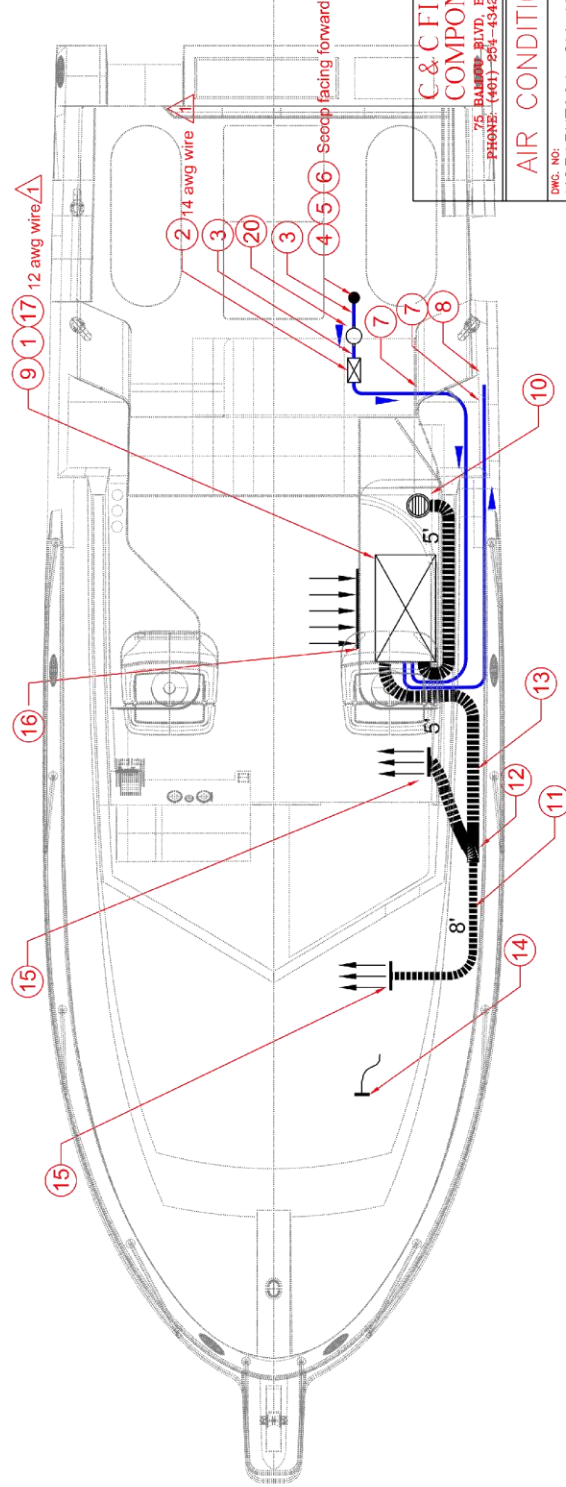

C & C FIBERGLASS COMPONENTS INC
 75 BALMORAL BLVD, BRISTOL, RI 02809 USA
 PHONE: (401) 254-4342 FAX: (401) 254-8978

AIR CONDITIONING SYSTEM

DWG. NO:	NC:315HT901-0M	Air Conditioning System
SCALE:	pg 1 of 2	DATE: 3/24/20
DRAWN BY:	RJP	REV. NO: 0

NC285 HT AIR CONDITION SYSTEM DOMETIC

DOMETIC

NC285HT AIR CONDITION SYSTEM DOMETIC

No.	DESCRIPTION	Part No.	U/M	Qty.
1	PLENTUM BOX BX A 16DTUJ/11.5X6.7X3/E5@2.	229801731	EA	1
2	PUMP ASSEMBLY PML500 115/50-60/1	225500005	EA	1
3	3/4" HOSE		EA	XX
4	3/4" GROCO BRONZE SEAWATER STRAINER	2641	EA	1
5	3/4" GROCO BRONZE SEACOCK 3/4	2703	EA	1
6	3/4" 90 DEGREE THRU HULL	2599	EA	1
7	5/8" Hose		EA	XX
8	5/8" ATTWOOD S.S. STRAIGHT THRU-HULL	66540-3	EA	1
9	DTU16-1161-410A 115V 60HZ(SEE DETAIL-A) (hull # 1-17)	205160160	EA	1
10	ROUND PLASTIC GRILLE 5" WHT W/ 5" DUCT	335078	EA	1
11	VINYL FLEX DUCT 5"	226600016	FT	10
12	WYE 5" X 4" X 4"	228700082	EA	1
13	VINYL FLEX DUCT 4"	226600014	FT	8
14	DISPLAY SMXHT DX GRAY BEZEL POLY EIKON GRAPHITE GRAY	222000242	EA	1
15	ROUND PLASTIC GRILLE 4" WHITE	332485	EA	1
16	RETURN AIR GRILL WITH FIXED VANES W/ FRAME & FILTER V12X14 PLASTIC	217316018	EA	1
17	DTG16-1171-410A-7MR 115V DUAL HZ (SEE DETAIL-A) (hull # 18+)	205160174	EA	1
18	BEZEL POLY BLACK	335441	EA	1
19	CABLE DISPLAY 20' ECU SPIN	222103005	EA	1
20	SEAWATER STRAINER Groco	ARG-750-S	EA	1
21	3/4" Pipe to Hose Adaptor Kellogg	9-0076DP5PLB	EA	2
22				
23				

C & C FIBERGLASS COMPONENTS INC

75 BALLOU BLVD, BRISTOL, RI 02809 USA
 PHONE: (401) 254-4342 FAX: (401) 254-8978

AIR CONDITIONING SYSTEM

DWG. NO: NC315HT901-OM Air Conditioning System
 DRAWN BY: RJP SCALE: pg 2 of 2 DATE: 3/24/20

THIS DOCUMENT IS THE PROPERTY OF C.C.F.C.I. AND IS NOT TO BE USED OR REPRODUCED IN WHOLE OR IN PART WITHOUT WRITTEN PERMISSION. REV. NO: 0

NC285 HT AIR CONDITION SYSTEM DOMETIC
 DOMETIC

REVISIONS

NO.	DESCRIPTION	DATE

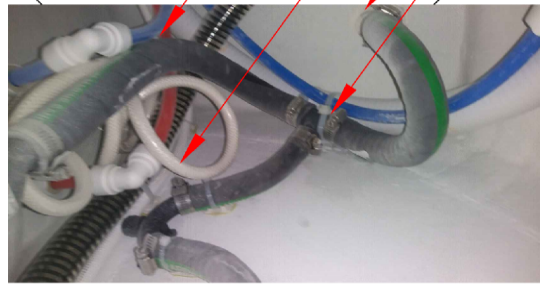
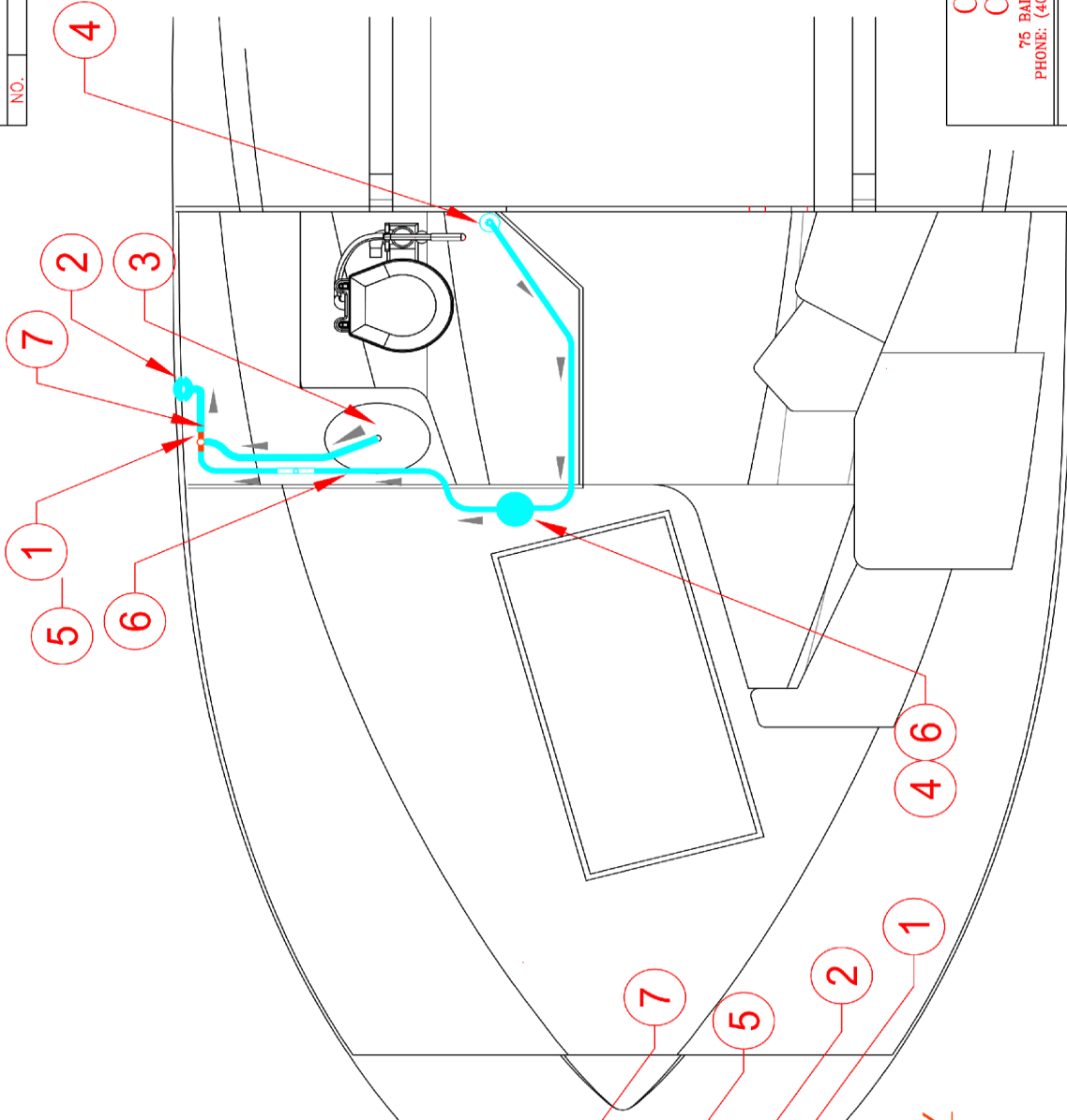

VIEW @ HEAD VANITY

C & C FIBERGLASS COMPONENTS INC
 75 BALLYOUL BLVD, BRISTOL, RI 02809 USA
 PHONE: (401) 254-4342 FAX: (401) 254-8978

GRAY WATER SCHEMATIC

DWG. NO: **NC315HT904-0M**
 DRAWN BY: **RJP** SCALE: **3/19/20**
 DATE: **3/19/20**
 THIS DOCUMENT IS THE PROPERTY OF C.C.F.C.I. AND IS NOT TO BE USED OR REPRODUCED IN WHOLE OR IN PART WITHOUT WRITTEN PERMISSION. REV. NO: **0**

NC315 HT GRAY WATER SYSTEM

LOOP AS HIGH
AS POSSIBLE

THRUHULL 1 1/8" 90 deg SS
NCPN: 2673

HOSE MPI 1 1/8"
NCPN: 145-1180

THRUHULL 1 1/8" 90 deg SS
NCPN: 2673

HOSE MPI 1 1/8"
NCPN: 145-1180

RULE 1100 BILGE PUMP
NCPN: 2311

LOOP AS HIGH
AS POSSIBLE

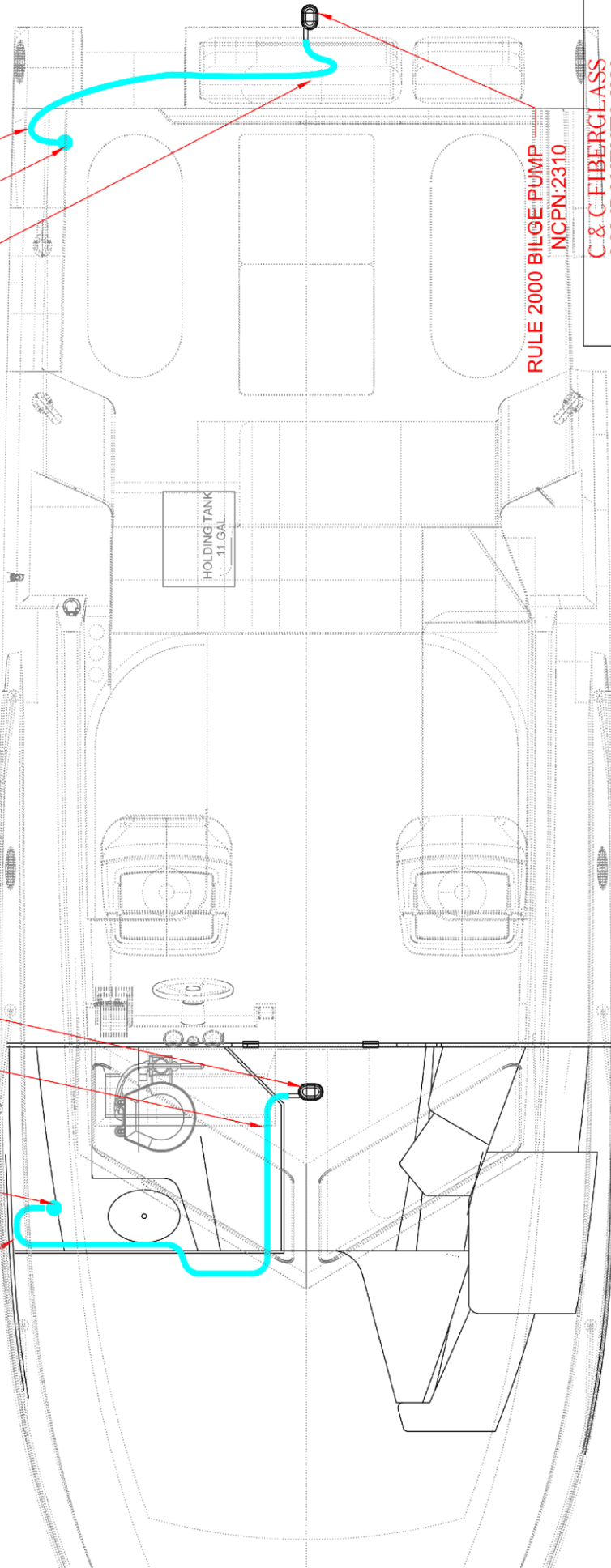

RULE 2000 BILGE PUMP
NCPN: 2310

C & C FIBERGLASS
COMPONENTS INC

75 BALLOU BLVD, BRISTOL, RI 02809 USA
PHONE: (401) 254-4342 FAX: (401) 254-8978

BILGE PUMP SYSTEM

DWG. NO:

NC315HT905-0M BILGE PUMP SYSTEM

DRAWN BY:

RJP

SCALE:

NONE

DATE:

3/21/20

REV. NO:

0

THIS DOCUMENT IS THE PROPERTY OF C.C.F.C.I. AND IS NOT TO BE
USED OR REPRODUCED IN WHOLE OR IN PART WITHOUT WRITTEN PERMISSION

REVISIONS

NO.	DESCRIPTION	DATE

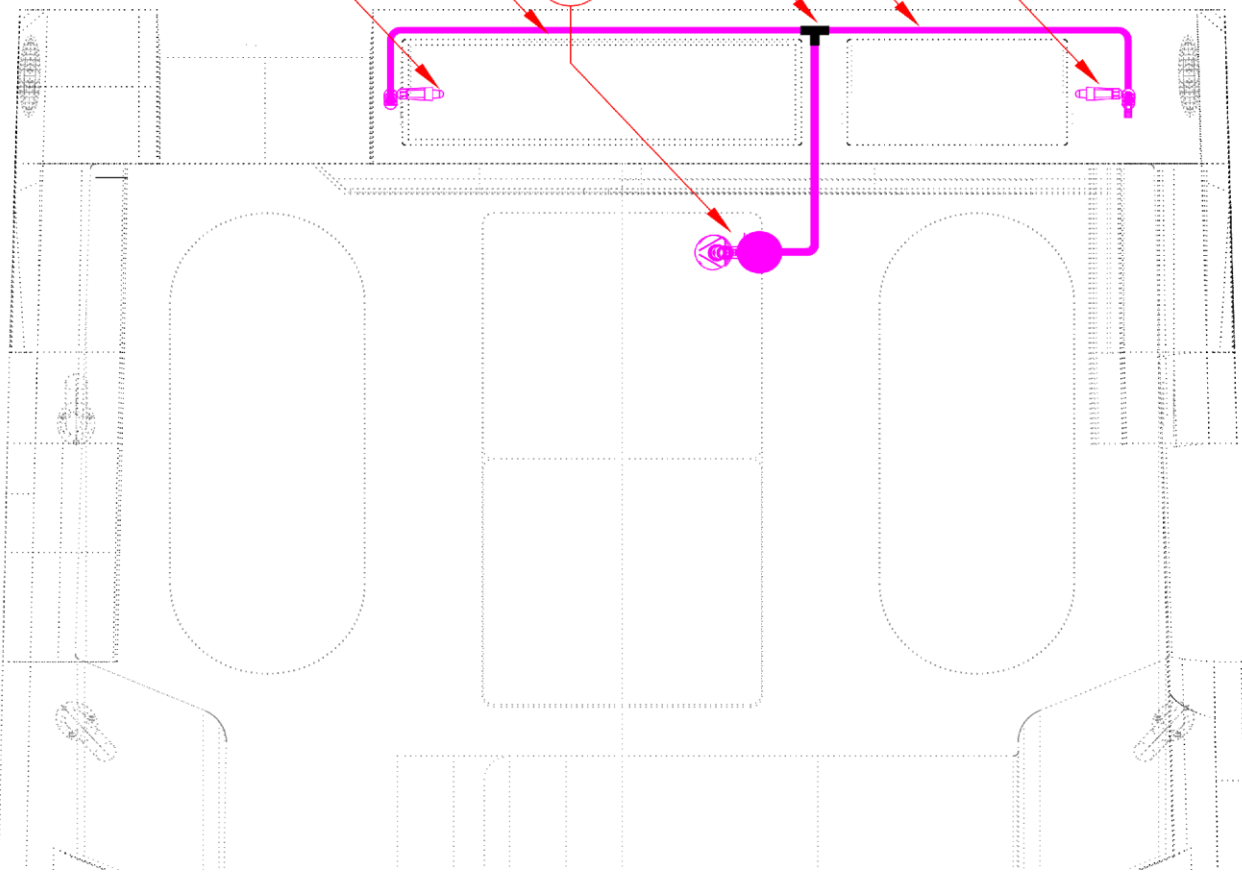

C & C FIBERGLASS COMPONENTS INC

75 BALLOU BLVD, BRISTOL, RI 02809 USA
 PHONE: (401) 254-4342 FAX: (401) 254-8978

SALT WATER WASHDOWN

DWG. NO:	NC315HT906-0M Salt Water Washdown	
DRAWN BY:	RJP	SCALE: NONE
DATE:	3/21/20	

THIS DOCUMENT IS THE PROPERTY OF C.C.F.C.I. AND IS NOT TO BE USED OR REPRODUCED IN WHOLE OR IN PART WITHOUT WRITTEN PERMISSION. REV. NO: 0

REVISIONS

NO.	DESCRIPTION	DATE
-----	-------------	------

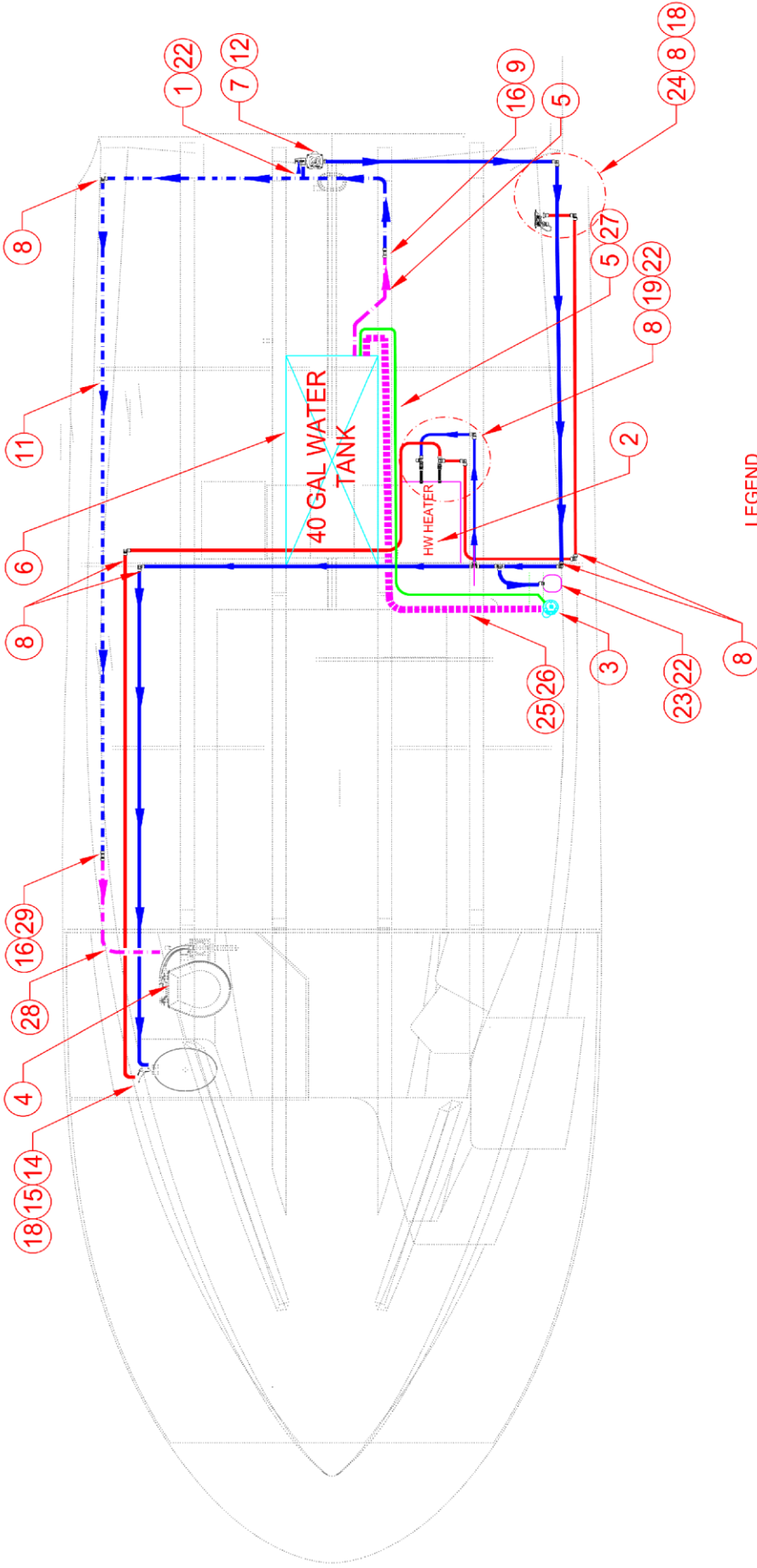

LEGEND

- WHALE BLUE COLD WATER
- WHALE RED HOT TUBING
- VENT HOSE
- 3/4" WATER HOSE CLEAR
- 1 1/2" WHITE
- WHALE BLUE COLD WATER LOW PRESSURE SIDE
- 3/4" WATER HOSE CLEAR LOW PRESSURE SIDE

C & C FIBERGLASS COMPONENTS INC
 75 BALLOU BLVD. BRISTOL, RI 02809, USA
 PHONE: (401) 254-4342 FAX: (401) 254-8978

FRESH WATER SYSTEM

DWG. NO:	NC315HT908-0M
SCALE:	NONE
DATE:	3/19/20
REV. NO:	0

CONTROLS

Steering

The boat is fitted with the standard Teleflex helm pump installed. This is a hydraulic steering system consisting of the helm pump and the steering ram when the engine is factory installed. The helm pump is secured to the console and the steering wheel operates the pump directly. The hoses are routed under the floor in a conduit running down the starboard side. Refer to the SeaStar manual for operation, system bleeding and maintenance.

The shift and throttle cables are mechanical in operation and are routed in the same conduit as the steering hoses. These are low friction cables for ease of operation.

Shift & Throttle

Refer to the manuals for detailed operation and maintenance.

Trim Tabs

In general, the boat runs perfectly without use of the trim tabs. However, in instances of strong crosswinds or asymmetric loading, you may need to use the trim tabs to level the boat athwart ships. The trim tabs are Lenco electric units and are wired using the Auto-Retract system which returns the tabs to the neutral (up) position when the engine is shut off. It is normal to hear the trim tabs retracting when the engine is shut down. The wiring for the trim tabs is run through the starboard side floor conduit.

Refer to the Lenco manual for further details.

Instrumentation

For each engine that is factory installed it is supplied with a tachometer and fuel gauge.

The engine has a key switch panel and an emergency stop switch panel with an emergency stop lanyard.

The lanyard (kill-switch) is a safety device worn around the wrist designed to cut electricity to an engine. Gasoline-powered engines require an electrical current to run, so when a kill-switch cuts the electricity from the battery the engine will immediately shut down.

FUEL SYSTEM

Fuel System Operation

This system has been designed to meet the EPA regulations using certified components to limit the fuel vapor emissions. Your fuel system provides the following benefits:

- Automotive style refueling, automatic nozzle shut-off. This system sends a signal to the pump nozzle to shut off before there is any spit-back or well-back through the fill opening.
- Overfill protection is included with each system, reducing the possibility of accidental fuel spills.
- Reduce hydrocarbon emissions through the use of a specially designed fuel fill. This fuel fill has a permanently attached cap with a positive closure mechanism with an audible click, to let you know when it is sealed.

Fuel Tank

Your boat is equipped with an aluminum fuel tanks that has a net capacity of 316.6 gallons and a useable capacity of 300 gallons. The fuel tank is different from the tank capacity marked on the tank from the manufacturer. The difference is the non-useable portion of the tank which results from the fuel in the tank that is below the pickup tube and the ullage area that has been incorporated into your tank. It is recommended that you follow all instructions regarding the filling of fuel tanks. Take time to read and understand all the fuel related information and warnings regarding gasoline and your boat, in the engine owner's packet. Fuel tanks with levels less than 1/4 full can cause engine stalling problems due to fuel starvation or by allowing sediment and dirt to enter the fuel supply lines. Keep the tank full and monitor the fuel level often to prevent this from happening. Your tanks are painted with a Macropoxy by the fuel tank builder this protects the aluminum from corrosion and creating aluminum oxide. Your fuel tank is also equipped with check valve built into your fill.

Fuel Vent

The fuel tank vent/p-trap is located on the hull side next to the deck fill. The vent serves as an over pressure/vacuum release. The fuel vent system also plays an important role in controlling the "FULL" level of fuel with the use of the FLVV (Fill Limit Vent Valve). Grade Valves have been added to the tank which allows proper ventilation of the tank when the boat is stored or trailered on a moderate incline, without fuel seepage.

Filling the Tank

This fuel system is designed to automatically shut off the fuel nozzle when the tank is full, similar to an automotive fuel system. The tank is filled when the fuel fill nozzle has shut itself off the first time. Attempting to fill the tank past this point may cause some of the components to not function properly or malfunction.

Note: During the first refueling event, the canister will heat up due to the carbon being activated for the first time.

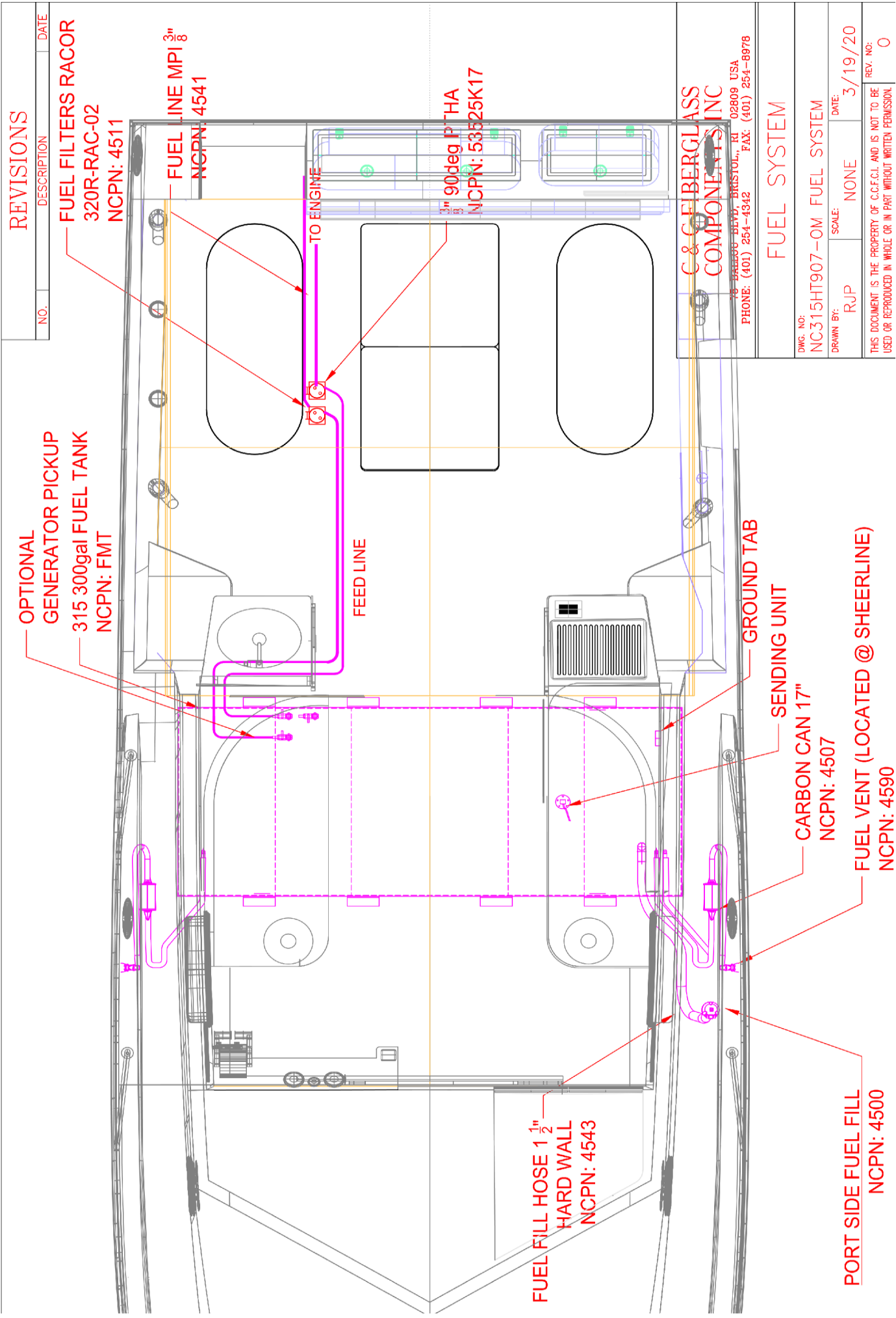

NO.	DESCRIPTION	DATE
	FUEL FILTERS RACOR 320R-RAC-02 NCPN: 4511	
	FUEL LINE MPI 3/8" NCPN: 4541	
	OPTIONAL GENERATOR PICKUP 315 300gal FUEL TANK NCPN: FMT	
	FUEL FILL HOSE 1 1/2" HARD WALL NCPN: 4543	
	3" 90deg PTHA NCPN: 53525K17	
	PORT SIDE FUEL FILL NCPN: 4500	
	FUEL VENT (LOCATED @ SHEERLINE) NCPN: 4590	
	CARBON CAN 17" NCPN: 4507	
	SENDING UNIT	
	GROUND TAB	

C & C FIBERGLASS COMPONENTS INC
 18 BRASSCO BLVD, BRISTOL, RI 02809 USA
 PHONE: (401) 254-4342 FAX: (401) 254-8978

FUEL SYSTEM

DWG. NO: NC315HT907-OM FUEL SYSTEM
 DRAWN BY: RJP SCALE: NONE DATE: 3/19/20

THIS DOCUMENT IS THE PROPERTY OF C.C.F.C.I. AND IS NOT TO BE USED OR REPRODUCED IN WHOLE OR IN PART WITHOUT WRITTEN PERMISSION. REV. NO: 0

CARBON CANISTER SYSTEM DECK FILL

99DFCC Series

INSTALLATION INSTRUCTIONS

11/04

69484 Rev. C SAVE THESE INSTRUCTIONS

CAUTION:

The vessel manufacturer must comply with the requirements of CFR 40 1060.202. Any questions can be directed to www.attwoodmarine.com

Failure to follow these instructions may result in accidental fuel system over-pressurization. Users must follow these instructions to ensure vessel function and operation

EMISSION-RELATED INSTALLATION INSTRUCTIONS

Failing to follow these instructions when installing the Attwood Carbon Canister System Deck Fills in a piece of nonroad equipment violates federal law (40 CFR 1068.105(b)), subject to fines or other penalties as described in the Clean Air Act.

FEATURES:

Attwood Carbon Canister System Deck Fills are sturdy, non-corrosive plastic. Bonding and grounding are not required because they are non-metallic. When latched, Deck Fills are water-resistant. They meet all requirements for ISO 10080, ABYC, and USCG. The 99DFCC Series Deck Fills are not certified for diurnal emission control. The use of a certified Carbon Canister for proper diurnal emission control is required to meet EPA diurnal emission control requirements. The Attwood 99DFCC Series Deck Fills are equipped with dual over pressure relief valves. These valves are intended only to prevent the accidental over pressurization of a fuel system and are safety devices only not for use as diurnal emission control devices.

Important safety instructions

(for all Attwood 99FL/99GV/99CC/99ICV/99DF components):

When a fuel system is configured with Attwood 99DFCC Series Deck Fills, the following safety precautions must be taken;

1. Use an Attwood 99ICV series Inlet Control valve between the liquid reservoir and the deck fill to prevent the accidental well back of fuel. Use only an Attwood 99ICV series Inlet Control Valve in-line with the fuel fill hose. No other fill hose valves should be installed in order to ensure the safety of the fuel system and vessel. The Attwood 99ICV series inlet control valves include features to allow vapor and liquid to pass the valve in order to ensure the system does not become accidentally over pressurized.

CARE AND MAINTENANCE

Care should be taken, when cleaning the boat, to prevent contaminating the valves and deck fill. Cleaning with only mild soapy water is recommended. All connections should be checked annually.

MANUFACTURER REQUIREMENTS

The information below applies only to EPA CFR 40 1060.135. The vessel manufacturer is responsible to meet all additional regulatory labeling requirements including EPA, CARB, USCG and others as necessary. The below information is for reference only. The vessel manufacturer should refer to CFR 40 for complete labeling guidelines. In order to meet the requirements of CFR 40 1060.135, the vessel must be labeled

with respect to evaporative emissions in the following manner when installing certified components;

Excerpt from CFR 40 1060.135

(a) You must affix a permanent and legible label identifying each engine or piece of equipment before introducing it into U.S. commerce. The label must be—

- (1) Attached in one piece so it is not removable without being destroyed or defaced.
- (2) Secured to a part of the engine or equipment needed for normal operation and not normally requiring replacement.
- (3) Durable and readable for the equipment's entire life.
- (4) Written in English.
- (5) Readily visible in the final installation. It may be under a hinged door or other readily opened cover. It may not be hidden by any cover attached with screws or any similar designs. Labels on marine vessels must be visible from the helm.

(c) If you produce equipment without certifying with respect to evaporative emissions, the equipment label specified in paragraph (a) of this section must—

- (1) State: "MEETS U.S. EPA EVAP STANDARDS USING CERTIFIED COMPONENTS." (2) Include your corporate name.

Below is an example of a label specified by CFR40 1060.135 for use with certified components;

**MEETS U.S. EPA EVAP STANDARDS USING
CERTIFIED COMPONENTS**

CORPORATE NAME

Please refer to CFR 40 1060.135 to review EPA vessel labeling requirements.

The NMMA has a program to supply OEM builders with labels. Please refer to the NMMA website below for further information regarding the NMMA label program;
www.nmma.org/certification/products/labelsanddecals.aspx

TWO-YEAR WARRANTY & LIABILITY

Generally: Attwood Carbon Canister System Deck Fills are covered by a two (2) year limited warranty from the date of a Vessel's first retail sale.

Pre-requisites to Warranty Eligibility: For the warranty coverage described herein to apply, the following conditions must be met:

- Component must have been properly installed per Attwood installation instructions; and
 - The component cannot have been altered or abused by Boat Company or its customers.
- Warranty Terms for Components:**

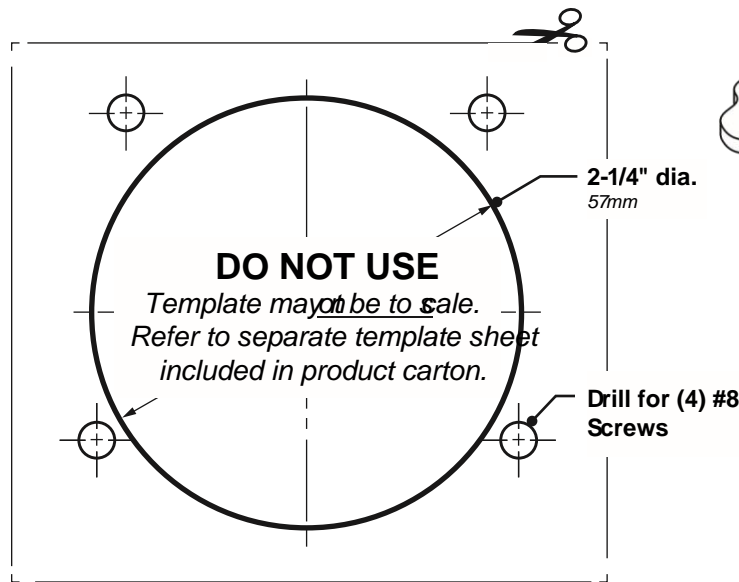
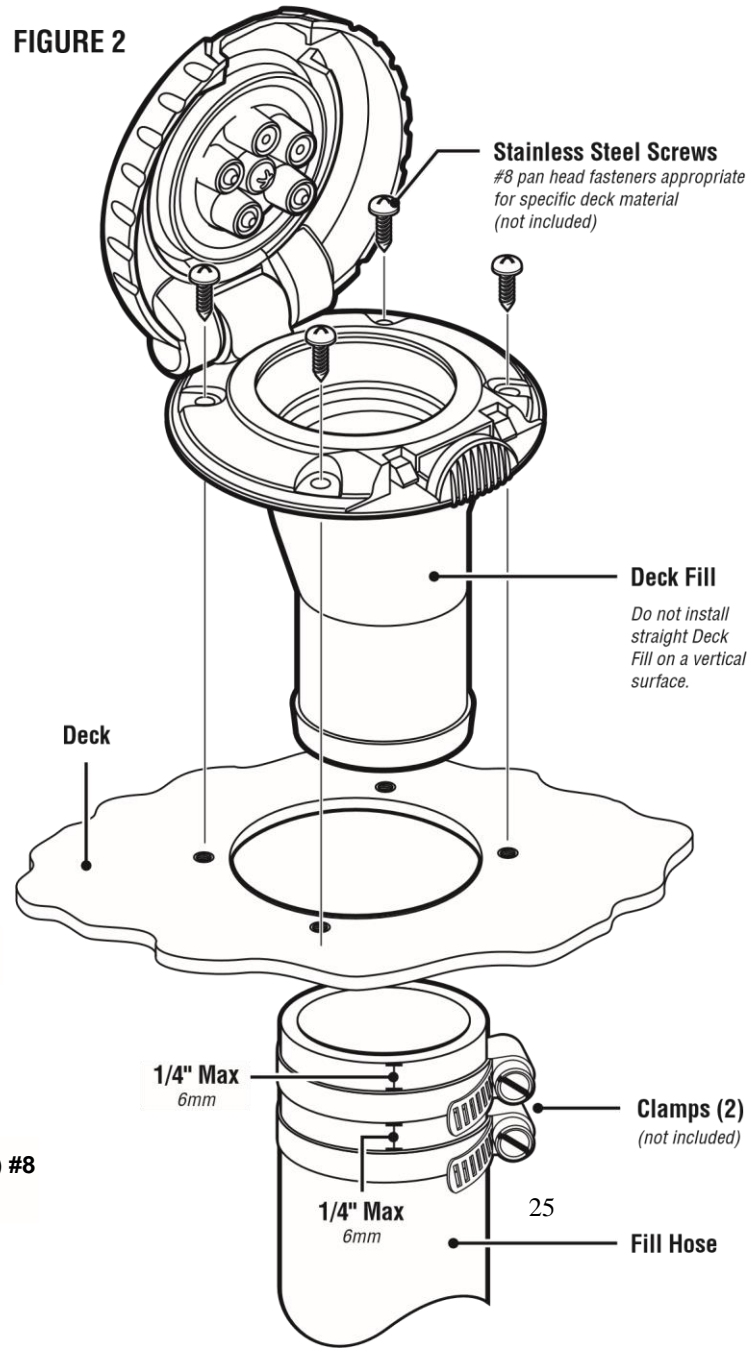
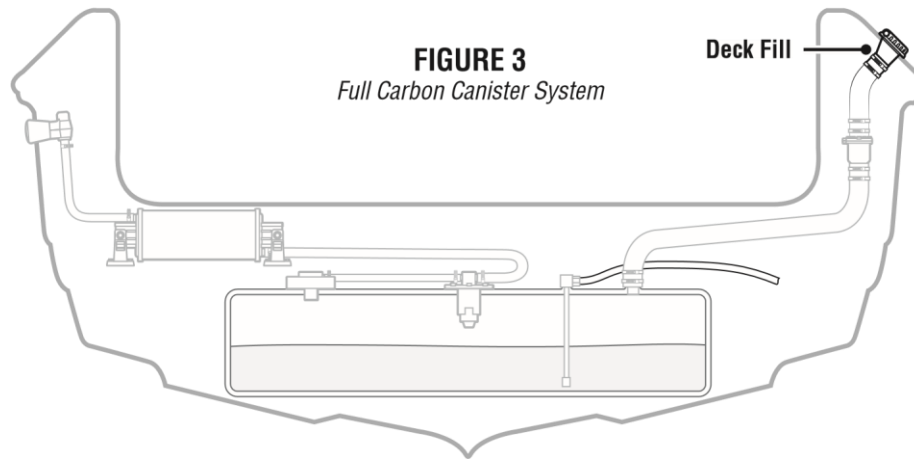

FIGURE 2



Attwood warrants that any Attwood Carbon Canister System Deck Fills are free from defects in materials and workmanship and are designed, built, and equipped to conform at the time of sale to Boat Company with the 40CFR.1060 requirements. For two (2) years from the date of the vessel's first retail sale, Attwood will, at its sole option, repair or replace any components that fail due to a defect in material or workmanship.



ATTWOOD PROVIDES NO WARRANTIES WITH RESPECT TO ANY PART OR COMPONENT NOT MANUFACTURED BY ATTWOOD, INCLUDING FUEL TANKS. Boat Company is responsible for the installation of all Systems, whether installed by Boat Company or under its direction.

A.B.Y.C.

American Boat & Yacht Council
(NMMA) Edgewater, Maryland 21037
www.abycinc.org

E.P.A.

401 "M" Street, SW
www.epa.gov

National Marine

Manufacturers Association 3069 Solomon's Island Road Washington, DC 20593 www.
231 S. LaSalle Street
Suite 2050
Chicago, IL 60604
www.NMMA.org

U.S. Coast Guard

Washington, DC 20460 iso.org www.uscgboating.org

ISO

011 Attwood Corporation

1016 North Monroe Lowell, MI 49331 www.attwoodmarine.com

VESSEL OPERATION

Weight

Always operate the vessel in a safe manner. The performance of the boat is affected by the amount of weight carried. Weight is comprised of many things including; fuel, people, gear, bait, fish and so forth. The greater the payload (variable weight) the slower the boat will go for a given RPM.

The operator should keep in mind the distribution of weight both fore and aft and athwart ships. In general, the following guidelines should be followed:

- Keep weight distributed evenly fore and aft to maintain vessel trim.
- Keep weight distributed evenly athwart ships to maintain vessel trim.
- Keep weight as low as possible.

When operating in heavy sea states and other adverse conditions, it is usually prudent to go slower as opposed to faster. The passengers will be more comfortable and there will be less chance of injury, sickness, etc.

Fueling

Due to the explosive nature of gasoline, certain precautions should be taken:

Before Fueling

- Properly secure the boat to the dock.
- Turn off engine and any other motors.
- Disembark all passengers.

NO SMOKING DURING FUELING

- Keep nozzle in contact with fill plate.
- Do not leave unattended.
- Do not spill fuel (use absorbent rag outboard of fill plate).

Do not overfill.

Fuel changes volume based on temperature after fueling.

- Secure deck plate.
- Clean any spilled fuel and dispose of rags properly on shore.

VESSEL OPERATION (continued)

Trim

There are many factors that influence the proper trim of your vessel. These include wind and wave forces, loading, heading and so forth. Proper trim applies to both the fore and aft and the athwart ships angle of the boat when running at a given RPM.

The boat should really be operated with a running angle of 1-2 degrees fore and aft and zero angle athwart ships. You have two main tools at your disposal to alter trim for given conditions and loadings. These are the engine and the trim tabs. While there exists an infinite number of setting combinations, a few guidelines are helpful as follows:

Engine Trim Down

- Lowers the bow in the water.
- Best position for starting and acceleration.

Engine Trim Up

- Raises bow from the water.
- Best position for fuel economy.

Generally, you should operate somewhere in the middle, for best all-around performance. When running in heavy following seas, special care must be taken with respect to trim and boat speed.

Trim Tabs

The NorthCoast 315 Hard Top is designed to run at the proper fore and aft angle by virtue of the bottom shape. The trim tabs are very effective in modifying the trim angle. Some helpful hints for using the trim tabs are:

- Use the bow up/bow down individually to modify athwart ships trim particularly useful when wind, sea or loading conditions are causing the boat to list.
- Use the bow up/bow down controls to change the running angle. This comes in handy when running in larger following seas.

VESSEL OPERATION (continued)

Starting

Refer to the included engine manual for detailed operation of the engine. A few top-level procedures should be observed as follows:

Before Starting

- Make sure the engine is lowered.
- Make sure there is sufficient clearance to the bottom.
- **Ensure that the propeller is free of debris and clear of obstructions and swimmers.**

Starting

- For a cold engine, move the throttle into the choke position. Advance throttle a few times to help prime the engine. Then leave the throttle approximately $\frac{1}{4}$ advanced.
- Push and turn the key.
- After engine is started, return the throttle to the neutral position.

For a hot engine, the steps are similar, although the throttle should not need to be advanced in the choke position. Leave the throttle in the neutral position and perform the starting steps.

After Starting

- Verify proper oil pressure in engine.
- Verify the proper charging level of engine.
- Visually inspect for cooling water circulation.

YOU MUST OBSERVE THE PROPER ENGINE BREAK-IN PROCEDURE AS DETAILED IN THE ENGINE OPERATORS MANUAL.

MAINTENANCE

The materials and workmanship of your NorthCoast 315 Hard Top will insure many years of operation and enjoyment. However, there are numerous steps you can take to keep your boat in top condition. Failure to take certain of these steps may result in shortened life span of certain equipment and may in certain cases, void the warranty.

Much of the equipment installed on your boat is separately warranted. Please refer to the individual OEM manuals for care and maintenance instructions, along with proper registration.

The easiest and perhaps most important regular maintenance step is to simply wash down the boat after each use with fresh water. This is of primary importance when operating in saltwater, but applies to freshwater use as well. Make sure to wash down the engine cowlings, canvas and cushions, rails, hull and deck.

Gelcoat

Regular cleaning and waxing will help preserve the finish on your boat for many years. The frequency at which this is needed will depend on your seasonal usage, area of operation and color.

- Use a mild detergent wash with fresh water.
- Rinse away all detergent residue.
- Do not use harsh or abrasive cleaners or other compound containing chlorine or ammonia.

Do not use acetone or other ketene-based solvents. Use denatured alcohol or kerosene and rinse the area being treated immediately. Wax the gelcoat surfaces with a high-grade wax, making sure to buff out all areas where wax has been applied.

MAINTENANCE (continued)

Inevitably you will get scratches on the gelcoat surfaces.

- Water sand minor scratches with #600 paper, then buff with polishing compound or equivalent.

Scratches that penetrate to the fiberglass substrate should be dealt with immediately. This is particularly important on scratches below the waterline. Your dealer or other industry professional best handles these repairs.

Whether operating in fresh or saltwater, marine growth is a problem. It will degrade performance, fuel economy and in severe instances can damage the gelcoat surface.

- Use a high-grade anti-fouling bottom paint that conforms to the regulations for operation in your boating area.
- Regular running of the boat at high speed when appropriate will rid the bottom of light growth.
- Regular washing of the bottom surfaces is recommended.

Other Exterior Components

Windows and Hatches

The clear surfaces of these components require the most attention. Clean metal frames per the instructions below for stainless steel and aluminum.

Rinse all acrylic surfaces with clean fresh water. **DO NOT** rub the surface in any way. Clean acrylic surfaces with mild detergent regularly (after rinsing).

Rinse again and pat dry with a clean chamois or cotton towel.

Grease and adhesives may be removed with kerosene, hexane or white gas. **DO NOT** use any other solvents or removal agents.

MAINTENANCE (continued)

Stainless Steel and Aluminum

All metals used on your NorthCoast are selected for their resistance to corrosion. However, none are corrosion proof.

What appears to be “bare aluminum” is actually anodized. When welded, the anodizing breaks down due to heat. Make sure to keep the weld joints waxed for best protection. See below for other general care instructions.

Certain structures may be “white aluminum”. This is actually a powder-coated surface. This provides optimal protection for weld joints and lends a clean appearance to the metal. Follow the general care instructions below.

Stainless Steel structures are highly corrosion resistant without the anodizing or powder-coating as in aluminum. However, welded areas are again more susceptible to corrosion. Keep these clean and waxed as with aluminum.

- Clean all metal components frequently with fresh water.
- Protect all surfaces with wax.
- Remove rust spots promptly with metal cleaner.
- Do not use coarse abrasives such as steel wool, soap pads, etc.
- Do not clean with acids or bleaches.
- Maintain powder-coated surfaces in a similar fashion to gelcoat surfaces.

Canvas

Clean with soft bristle brush and fresh water. Do not use detergent soap. Use a neutral soap when needed. Remove bird droppings and other stains promptly before they set in and degrade the performance of the material.

Vinyl

Wipe down regularly with mild soap and fresh water. Do not use any special cleaners or solvents.

MAINTENANCE (continued)

Corrosion

When operating in saltwater for extended periods, check the transom mounted grounding anode for significant degradation. Replace at 50% level. Check the sacrificial anodes in the engine. Check all metal thru-hull fittings when hauled out. Ensure that the engine is tilted full up when the boat is left moored or docked.

Significant/frequent signs of pitting or other metal degradation may be indicative of a corrosion problem either with your vessel directly or due to other stray currents present in the marina or the marina electrical system.

Winterization, Storage and Commissioning

Proper storage of your boat is equally important as in season maintenance. Some recommended steps are provided to assist in this. Your local situation may require further measures.

Winterization and Storage

- Orient the hull so any water from rain, snow and condensation drains aft.
- Remove the garboard drain plug.
- Drain all water from water systems, including the water tank, hoses and fittings.
- Make sure the fuel tank is full. You may want to add a stabilizer to prevent algae growth.
- Ensure that bilge pump system is drained.
- Treat all uncoated metal parts with rust inhibitor.
- Winterize the toilet system per manufacturer's instructions.
- Empty holding tank.
- Remove batteries and store in warm, dry environment. Do not store on concrete floor.
- Winterize engine(s) per manufacturer instructions.
- Cover with shrink wrap or store in covered area.
- Ensure that the boat is properly blocked. If stored on a trailer, block this up to un-weight tires.

CONSTRUCTION DETAILS

- **HULL AND DECK MATERIALS**

- **TECHNOLOGY**

NorthCoast uses some of the most advanced technology in the marine industry in the design and construction of all NorthCoast. Only top quality, top performance materials which have been thoroughly tested are used.

- **GELCOAT**

To protect the laminate from the environment, all NorthCoast utilize Isophthalic (ISO) gelcoat. ISO gelcoats yield a denser, more frequently branched molecular network which inhibits migration of water molecules. Because of their structure, these gelcoats offer superior resistance to moisture penetration, blistering and fading. They are formulated to yield slightly more flexibility than most gelcoats which helps to resist cracking. Tests also indicate that ISO gelcoats produce the highest, most durable gloss finish, and retain it despite severe environmental exposure.

- **GLASS FIBERS**

High performance glass fabrics are used throughout the sandwich-type laminate. They offer superior strength and stiffness when compared to conventional cloth and woven roving materials used by many other builders. In high stress areas, bi-axial fabrics, which can be oriented to yield maximum strength and stiffness are used. These fibers require less resin and therefore, produce stronger, lightweight structures.

- **VINYL ESTER RESIN**

A special vinyl ester resin is used as a barrier behind the gelcoat to further resist moisture penetration. By excluding moisture, blistering cannot occur. The vinyl ester resin is also resilient like the gelcoat to increase crack resistance. The vinyl ester resins, in combination with ISO gelcoats and carefully selected fibers, produce the most blister resistant hulls available today.

- **POLYESTER RESIN**

A high quality polyester resin is used to complete the rest of the laminate. Selected for its compatibility with the high-performance fabrics used, this resin provides a high-strength, durable laminate, resistant to cracking and fatigue. Again, the correct balance of properties between each component is designed to assure that the high strength and stiffness will be retained throughout the life of your vessel.

- **HULL AND DECK CONSTRUCTION**

- **SANDWICH DESIGN**

Sandwich construction is used in all NorthCoast decks to produce stronger, lighter, faster performance cruising boats. A fiberglass sandwich functions similarly to an "I" beam. "I" beams are used for construction because they make the most efficient use of materials based on structural criteria and reduce overall weight. The inner and outer skins of the sandwich function in the same ways as the top and bottom flanges of the "I" beam, and the core functions similarly to the web of the "I" beam. This means lighter decks can be produced which are actually stiffer and stronger.

- **SOLID HULL BOTTOMS**

Peace of mind comes with not using core in our hull bottom construction. While other competitors core their bottoms, they are exposing themselves to long-term problems, with any significant impact through the thin external laminate this will allow water to penetrate and saturate the core and will act as a splitting wedge in cold climates where freezing is a major concern. At NorthCoast our hull bottoms are SOLID laminates and you will never have the issues that you would experience with cored bottoms and that in itself is peace of mind.

- **CORE MATERIAL**
Many different cores are available for use in sandwich construction because it has superior physical properties over all other cores and is resistance to water penetration and savings in weight.
- **QUALITY CONTROL**
Great care is taken in controlling the quality during the production of laminated parts. The following steps are necessary to guarantee that the physical properties used in the design is the same as those which are built into the part.
- **GELCOAT TESTING**
Gelcoat application is carefully controlled to ensure the proper coating thickness and performance. This is important when considering blister resistance. Proper catalyzation, thickness and low porosity are key in producing a finish that will best resist the osmotic passage of moisture. Control of catalyzation is also very important for weatherability.
- **HULL AND DECK ASSEMBLY**
 - **TABBING**
Major structural framing and bulkheads are glassed to the hull and deck using double bias glass fabric. This provides for an integral bond between the hull, deck and frames.
 - **HULL AND DECK FLANGES**
Laminate thicknesses are increased in the hull and deck flanges to distribute the high local stresses that are produced in these areas. Fasteners and adhesives are used to insure a strong watertight joint between these flanges.
 - **HULL/DECK JOINT**
Before fastening, 3M-4000 high-strength urethane adhesive sealant is applied to the flanges to totally seal the joint. This combination of fastening every six inches and bonding creates an unusually strong, watertight hull to deck joint.
 - **HARDWARE REINFORCING**
All internal and external hardware connections are engineered individually for long lasting integrity. Additional laminate reinforcing and backing plates are used as required to ensure reliable fastening for all deck hardware.
 - **THRU-HULL FITTINGS**
Thru-hull fittings are constructed of the highest quality glass reinforced nylon available for above the waterline application and solid bronze for below. 3M-4000 sealant is used to create a watertight seal between the hull and the thru-hull fitting. The hull laminate core is sealed around the fitting to prevent water from entering the core.

COMMISSIONING CHECKLIST

Page 1 of 2

Preliminary

1. Check hull carefully for damage in transit
2. Check propeller, nuts, cotter pin, and zincs
3. Check loose gear on boat

Pre-Launch

1. Read Owner's Handbook and OEM manuals
2. Cover cushions or remove them from boat in order to protect them during commissioning
3. Install transducers
4. Check battery charge with battery test switch on the electrical panel
5. Close seacocks
6. Check all hose clamps & tighten as required
7. Check engine oil, transmission & coolant level
8. Install portlight screens
9. Locate: Ignition keys, Bilge Pump
10. Touch up bottom paint
11. Acquire: Dock Lines, Fenders
12. Stow remaining loose gear

Launch

1. Reinstall garboard drain
2. Check for leaks
3. Check operation of seacocks
4. De-winterize engine and head
5. Check expiry dates on flare kits, fire extinguishers and other like equipment

Systems Check

1. Fill water tanks--flush tank twice to eliminate non-toxic antifreeze
2. Check water pressure system
3. Fill fuel tanks

COMMISSIONING CHECKLIST

Engine Start

- 1. Run engine under load
- 2. Check operation of all pumps--electrical & manual
- 3. Check operation of head--no leaks
- 4. Check optional Y valve for correct discharge
- 5. Check all AC/DC options for correct operation
- 6. Acquire and secure ground tackle
- 7. Read engine owner's manual
- 8. Check alignment and hook up couplings
- 9. Ignition
- 10. Start engine
- 11. Check oil pressure, water temperature, charging gauges--Check engine manual for proper operation
- 12. Check fuel filter for bubbles--Check fuel lines for leaks
- 13. Check transmission for operation

Trial Run

- 1. Monitor engine performance
- 2. Check bilge for leaks
- 3. Check and/or calibrate all instruments as needed

Clean Up

- 1. Clean bilge
- 2. Vacuum boat throughout
- 3. Wash down deck & hull

Work Performed by: _____ Checked by: _____ Date: _____

Return a signed copy of this commissioning checklist to NorthCoast Customer Service Department.

STANDARD EQUIPMENT 315

- 12 YEAR STRUCTURAL HULL WARRANTY
- "NO WOOD" CONSTRUCTION
- WHITE HULL
- CORED DECK AND MOLDED HULL LINER W/TWO TONE MOLDED NON-SKID (WHITE/GRAY/TAN)
- FOAM COMPOSITE GRID STRINGER SYSTEM
- HIGH DENSITY FOAM CORED TRANSOM
- HIGH IMPACT RUB RAIL

DECK

- MOLDED BOW SPRIT W/ ROLLER & CHAIN LOCK
- STAINLESS STEEL BOW RAIL
- STAINLESS STEEL HAND RAILS
- HIGH-QUALITY STAINLESS-STEEL DECK HARDWARE
- ANCHOR WINDLASS W/ FWD. FOOT CONTROLS

PILOTHOUSE

- CUSTOM FIBERGLASS WINDSHIELD FRAME
- COATED OPENING WINDSHIELDS
- SLIDING SIDE WINDOWS W/ SCREENS
- PANTOGRAPH WIPERS W/ MULTIFUNCTION SWITCH (P&S)
- VENT HATCHES ON HARD TOP
- LED NAVIGATION LIGHTS
- COURTESY LIGHTS & DOME LIGHTS
- DUAL TRUMPET HORN
- RITCHIE COMPASS @ HELM
- DC PANEL AT HELM W/ USB & DC PLUGS

- TRIM TABS W/ LED POSITION INDICATORS
- (4) CUP HOLDERS
- WET SOUNDS ENTERTAINMENT SYSTEM
- STEREO CABIN SPEAKER SYSTEM
- TODD LADDER BACK HELM SEATS P&S
- SEATING AFT OF HELM SEAT IS INSULATED
- SEATING AFT OF COMPANION SEAT IS STORAGE
- AC/DC REFRIGERATOR DRAWER TO PORT
- PHONE, WALLET, KEY BINS
- CUSTOM AFT CANVAS ENCLOSURE WITH REMOVABLE LARGE WINDOWS TO P&S AND CENTER ROLL-UP DOOR

CABIN

- DOUBLE BERTH TO STBD W/ STORAGE BELOW
- REMOVABLE INSERT & STEP TO PORT
- STORAGE LOCKERS TO PORT
- 6'8" ATHWARTSHIP AFT BERTH BELOW HELM AREA
- OPENING PORTS W/ SCREENS (4)
- FWD. HATCH W/ SCREEN
- LED CABIN DOME LIGHTS (DAY/NIGHT)
- LED READING LIGHTS: TWO AT EACH BERTH

HEAD

- ELECTRIC-FLUSH HEAD SYSTEM
- 29GAL. HOLDING TANK, MACERATOR, SHOWER & VANITY SINK
- LED CABIN DOME LIGHTS (DAY/NIGHT)

- 110V GFI OUTLET

COCKPIT

- KENYON COCKPIT GRILL W/ (2) DRAWERS FOR TOOLS, FLATWARE, ETC.
- MOLDED SINK W/ (6) TACKLE BOXES BELOW
- PORTSIDE TUNA DOOR
- CUSTOM STAINLESS ROD HOLDERS (4)
- CUP HOLDERS (4)
- COCKPIT BOLSTER PACKAGE W/ NORTHCOAST LOGO
- FRESH WATER SHOWER AT TRANSOM
- SALT WATER WASHDOWN AT TRANSOM
- STORAGE IN STEPS TO FORE DECK P&S
- REMOVABLE COCKPIT SOLE
- CENTER ACCESS COCKPIT HATCHES TO MECHANICAL AREA
- 26-GAL BLUE LIVE WELL W/ LIGHT & CLEAR LID
- 19-GAL BLUE LIVE WELL W/ LIGHT & CLEAR LID
- 58-GAL MACERATED FISH BOXES (2)
- STEP-THRU TRANSOM W/DOOR TO STARBOARD
- FULL COCKPIT PERIMETER GUTTER SYSTEM W/ OVER-SIZED SCUPPERS
- SWIM LADDER ON TRANSOM BRACKET

MECHANICAL

- THREE BATTERY SYSTEM AGM31
- PRESSURE COLD WATER SYSTEM
- SHORE POWER AC/DC PANEL AT HELM

- USB & DC PLUGS
- 110V GFI OUTLET IN HEAD
- 110V OUTLETS IN CABIN (3)
- SHORE POWER CHORD 50'
- BATTERY CHARGER 12V 20AMP
- INVERTER 3000W
- AUTOMATIC BILGE PUMPS FWD. 1100 & AFT 2000

ADDITIONAL FACTORY OPTIONS

- Hull Color of choice w/ boot stripe
- Bow thruster 1.5kw 28kfg
- *Air conditioning Dometic 16k BTU
- Generator 3.5kw Gas
- Hot water w/ city water hook-up
- 24" LED TV
- Rocket launchers on hard top (6)
- Rocket launchers on transom (6)
- Outriggers Rupp Top Gun
- Additional rod holders (Pair)
- Aft Facing Cockpit Folding Seats (2)
- 60" Folding Cockpit Seat
- Teak Sea Deck flooring material
- Gray rub rail
- Rub rail w/stainless steel insert
- YAMAHA Helm Master
- Outboard HP: T250 | T300

*Requires Shore Power option OR generator

Options, freight & taxes extra. Prices, specifications, equipment and options may change without notice.

Please contact your nearest [dealer](#) .

Specifications & General Information

Dealer: _____

Vessel Registration Number: _____

HIN: _____

Hull Color: _____

Boot Top Color: _____

Deck Color: _____

Non-Skid Color: _____

Warranty Registration Date: _____

Radio Call Numbers: _____

Engine One S/N: _____

Propeller Size: _____ D x _____ P x _____ Blds

Trailer Make: _____

Trailer S/N: _____

Insurance Company: _____

Policy #: _____

Insurance Agency: _____

Phone: _____

NORTHCOAST BOATS WARRANTY POLICY

C & C Marine Inc.

Manufacturer of NorthCoast Boats™

75 Ballou Blvd. Bristol, RI, 02809

Tel: 401-254-4342 Fax: 401-254-8978

NORTHCOAST BOATS™ LIMITED WARRANTY- RECREATIONAL BOATS

1. The "Federal Boat Safety Act of 1971" requires all boat manufacturers to maintain a record of all first retail purchasers and their current addresses for the purpose of notification in case of defective parts or equipment or in case of noncompliance with standards or regulations set forth by this act. Under the act, the failure to complete and return your factory warranty card for our records will waive your right to notifications of defect and/ or repair at manufacturer's expense.

2. Hull Warranty: C & C Marine, Inc. (Manufacturer of NorthCoast Boats™) warrants to the first purchaser and any subsequent owner that the hull and stringers will be free from structural defects in materials and workmanship for a period of TWELVE (12) YEARS from date of purchase from dealer or manufacturer subject to the conditions set forth below.

3. One-year components warranty: C & C Marine, Inc. warrants to the purchaser or owner that for one year (1) after the date of purchase, all boat components manufactured by C & C Marine, Inc. shall be free from defects due to material or workmanship under normal noncommercial use.

4. Exclusions:

A.) This warranty will apply only to boats used in normal recreational boating activities. Boats used in any governmental, commercial or revenue producing activity of any kind, including but not limited to charter or rental fleets, are excluded from coverage under this warranty.

B.) Parts or accessories that were dealer or owner installed items are the responsibility of the dealer or owner.

C.) This warranty does not apply to cosmetic defects, including but not limited to, gelcoat cracking, chalking, crazing, discoloration, yellowing, blistering, nor graphics or coloration problems.

D.) Fiberglass blistering attributable to water penetration of the fiberglass (osmosis) is specifically excluded from this warranty coverage.

E.) This warranty does not apply to problems caused by improper maintenance, abuse, vandalism, lack of maintenance, improper storage, improper hauling or transport, normal wear and tear, misuse, neglect, accident, corrosion, electrolysis, improper operation or Acts of God.

F.) Windshield breakage and/ or leakage is not covered by this warranty.

G.) Fuel contamination of any kind is specifically excluded from this warranty.

H.) Hulls modified in any way or hulls on which the engine installation has been modified in any way are not covered by this warranty.

I.) This warranty does not cover tears, cracking, fading, discoloration, or mildewing of curtains, cushions, tops, headliners, or other fabric or upholstered items.

J.) This warranty does not cover components not manufactured by C & C Marine, Inc., whether or not warranted by the other manufacturer, even if installed by C & C Marine, Inc., including but not limited to engines, propellers, appliances, and air conditioning. Warranties provided to generator sets, controls, electronics, batteries, appliances and air conditioning. C & C Marine, Inc. by component manufacturers shall be passed on to purchaser to the extent that such transfer is permitted by manufacturer.

K.) Haul out, launch and transportation charges.

L.) The cost of removal or reinstallation of parts or disassembly of units to repair or replace components covered by this warranty.

M.) Damage caused by an improper trailer or mismatching of a NorthCoast Boat™ to a trailer, failure to properly secure the boat to the trailer, or failure to use a lower unit support device when transporting the boat.

5. This warranty shall not apply to any boat that has been overpowered according to the maximum manufacturer recommended engine horsepower specifications on the capacity plate affixed to the boat, if one shall appear on said boat.

6. Speeds, fuel consumption, weights and other characteristics of performance are strictly estimating and therefore cannot be and are not guaranteed. Any oral statement or printed statement regarding any performance characteristic of the boat or its components shall be considered an estimate only and shall not be relied upon as express warranty as a basis of the bargain for the boats or its components.

7. C & C Marine, Inc. reserves the right to improve its boats at any time through modifications in design, use of new materials and / or incorporation of new methods of manufacture without any obligation to incorporate such changes into boats of prior manufacture.

8. C & C Marine, Inc.'s obligation under this warranty is limited to repairing or replacing, at our option, hulls that C & C Marine, Inc. determines to be structurally defective. This is your sole and exclusive remedy.

9. This warranty and the rights and remedies under it is exclusive and is given in place of all other warranties, whether expressed or implied, including any implied warranty of merchantability or fitness for particular purpose, whether arising by law, custom, conduct, or usage of trade. Purchaser's remedies shall be limited as stated herein and C & C Marine, Inc. shall not be liable for any incidental, consequential or indirect damages or losses resulting from defects.

10. This limited warranty gives purchaser specific legal rights. Purchaser may have other rights which may vary from state to state. In the event that implied warranties are found to exist under the laws of a particular state notwithstanding the exclusions contained herein, the duration of any such warranty shall be limited to the duration of the applicable limited warranty stated herein.

11. The selling dealer is not an agent of C & C Marine, Inc. or a co-warrantor and is not authorized by C & C Marine, Inc. to amend or modify this warranty in any manner.

OWNERS RIGHTS AND RESPONSIBILITIES

12. The owner must notify C & C Marine, Inc. or an authorized C & C Marine, Inc. dealer of any defect in material or workmanship within thirty (30) days of discovery.

13. C & C Marine, Inc. reserves the right to require that all repairs and / or replacements be done by our factory in Bristol, Rhode Island., the authorized dealer who originally sold the boat, or at a repair facility that we choose. Boats or parts will be transported to the selected repair facility at the owner's expense.

Haul out fees are the responsibility of the owner. Reimbursement to repair facilities under the warranty will be based on a rate and schedule established by C & C Marine, Inc.

14. In no event will C & C Marine, Inc be liable for any incidental, special, or consequential damages or for any other loss, damage, or expense of any kind, including loss of profits or enjoyment.

WARRANTY REGISTRATION

15. Proper warranty registration is required to validate the warranty. The warranty registration must be filled out by the first purchaser and the authorized dealer at the time the boat is purchased. This warranty shall not be valid unless that factory warranty paperwork is properly executed and mailed within ten (10) days of the purchase of the NorthCoast boat. Failure to register properly could void the warranty. This warranty registration is for recreational boats only.

TRANSFER OF WARRANTY

16. Coverage remaining under the limited warranty period may be transferred to a subsequent purchaser within the applicable limited warranty period. Any subsequent owners during the warranty period must provide C & C Marine, Inc. **In writing**, the HIN, name and address of new owner, and the name of name of the previous owner. A request for transfer must be made in writing to C & C Marine, Inc., 75 Ballou Blvd., Bristol, RI 02809 within 15 days of transfer.

Please send a copy of the prior owner's information. The new owner and purchaser agree to all items and conditions of the warranty. Only the unused portion of the warranty will apply to the new owner. The new owner must fill out the **Transferable Warranty Form**.

NorthCoast Boats
Warranty Registration Form

**IN ORDER TO REGISTER WARRANTY, THIS FORM MUST BE COMPLETED AND
SENT WITHIN 10 DAYS OF DELIVERY TO:**

**C & C MARINE, INC.
75 BALLOU BLVD.
BRISTOL, RI 02809
ATTN: CUSTOMER SERVICE- WARRANTY DEPT.**

Buyer' Name: _____ **Phone #:** _____

Buyer's Address: _____

Year & Model: _____ **Date of Delivery:** _____

Hull Identification #: _____ **Invoice #:** _____

Engine Port: _____ **Stbd:** _____

Serial # Port: _____ **Stbd:** _____

Outdrive Port: _____ **Stbd:** _____

Serial # Port: _____ **Stbd:** _____

Selling Dealer: _____ **Phone#:** _____

Dealer Address: _____

PDI (Boat and Engine) Performed: _____

Buyer's Signature*: _____ **Date:** _____

Dealer's Signature: _____ **Date:** _____

*** Buyer acknowledges by his/her signature that he/she has read the warranty statement and agrees with the terms and conditions stated therein. The buyer also acknowledges the receipt of a copy of this warranty at the time of delivery.**

NorthCoast Boats
Warranty Transfer Form

IN ORDER TO VALIDATE TRANSFER OF WARRANTY, THIS FORM MUST BE
COMPLETED AND SENT WITHIN 15 DAYS OF SALE TO:

C & C MARINE, INC.
75 BALLOU BLVD.
BRISTOL, RI 02809
ATTN: CUSTOMER SERVICE-WARRANTY DEPT.

New Buyer: _____ Phone #: _____

New Buyer's Address: _____

Original Buyer: _____ Phone #: _____

Original Buyer's Address: _____

Year & Model: _____ Date of Sale: _____

Hull Identification #: _____

Selling Dealer: _____

Selling Dealer's Address: _____

Selling Dealer's Signature: _____ Date: _____

New Buyer's Signature*: _____ Date: _____

***New Buyer acknowledges by his/her signature that they have read the warranty statement and agrees with the terms and conditions stated within. The New Buyer acknowledges the receipt of a copy of this warranty at the time of sale.**

Amount of chlorine compound required for 100-ppm solution.

Gallons Of Solution	Chlorinated Lime 25% (ounces)	High Test Calcium Hypochlorite 70% (ounces)	Liquid Sodium Hypochlorite 1% (quarts)
5	0.3	0.1	0.2
10	0.6	0.2	0.4
15	0.9	0.3	0.6
20	1.2	0.4	0.8
30	1.8	0.6	1.2
50	3.0	1.0	2.0
100	6.0	2.0	4.0

Reprinted from ABYC Appendix H-23.

RECOMMENDED TOOLS FOR ONBOARD MAINTENANCE

- Screw Drivers
 - a. Straight - stubby - offset - jewelers set
 - b. Phillips - stubby - offset - jewelers set
- Set Adjustable Wrenches
- Set Open/Box standard & metric to 1" and 19 mm
- Socket Set standard & metric to 1" and 19 mm
- Channel Locks: 12" and largest available
- Pliers
- Needle Nose Pliers - small and large
- Wire Strippers/Crimps
- Vise Grips - large and small
- Utility Knife
- Multi-Meter
- Spare Parts Kits

HOW TO LOAD YOUR BOAT ON THE TRAILER

1. Drop and Go

Drop the driver of the tow vehicle off at the end of the dock to go retrieve the rig. Idle out away from the ramp. Or, if you won't be impeding others, pull alongside the far end of the dock. Meanwhile, attach a line to a bow cleat, and one to the stern — especially important if there is wind or current.

2. Evacuate

When you see your rig pulling into position to back down the ramp, get everyone off the boat except the operator. Leave the gear aboard; that's for later. Hold the lines to keep the boat in position just beyond the reach of the trailer. Signal the vehicle driver when the trailer has backed far enough down the ramp for loading. He/she should put the vehicle in park, engage the parking brake, and leave the engine running.

3. Drag or Drive

Many boats can be floated most of the way onto the trailer without much effort. But if your boat is large or susceptible to being pushed about by crosswinds, you may have more control if you SLOWLY drive it on to the trailer. Do not apply the throttle to "power load," as this practice washes away the material under the end of the ramp leading to it eventually collapsing.

4. Winch It On

At this point, either you, or the driver needs to position themselves on the trailer tongue to attach the winch strap or cable to the bow eye of the boat, and crank the boat fully onto the trailer. When the bow is snug against the winch post, attach the safety chain.

5. Pull Up Slowly

Have the driver pull slowly up the ramp, pausing to allow you to raise the outboard or sterndrive if necessary. Follow the tow vehicle to the loading zone.

6. Unload & Drain

Don't forget where you put the plug!

Pull the plug and drain any live wells. You want any water in the boat to end up back in the same body of water it came from to minimize the risk of transferring invasive species. Do this first so there's plenty of time for the boat to drain while you load your gear into the tow vehicle, attach transom tie-downs to the transom eyes, lower any bimini or antennas, or anything else that needs to happen before the boat can hit the highway. Don't forget to plug in the trailer lights!

NEVER STRAP OVER THE BOAT THIS WILL DAMAGE THE GELCOAT AND AVOID ALL WARRANTIES.